

CUTEC NEWS

FACTS · INFORMATION · ANALYSES

We wish you all
a Happy New Year!



Nr_1

www.cutec.de

February 2008

Energy from biomass – the solution to our energy problems?

What some market experts had been predicting for oil prices before the end of last year has finally happened – the oil price has reached 100 dollars a barrel. As consumers, we can see fuel prices at the pumps rising almost daily. As a consequence, the public debate has focussed on the requirement to reduce tax on fuels and on the discussion of alternatives to oil. One option to date, costing up to around \$ 60 a barrel, is coal liquefaction, but this is considered unprofitable and its low degree of efficiency and associated elevated levels of carbon dioxide have attracted criticism. As a result, the use of biomass to obtain raw materials for fuels and chemicals is back in the frame. Two years ago I wrote an article for this newsletter entitled “Green Gas and Art-Fuel” which addressed the use of biomass as a fuel substitute for crude oil – in other words, at a time when the oil price was at around 60 dollars a barrel, but analysts were already forecasting the price rise for coming years which has now occurred. How has our knowledge come on in the past two years with regard to the use of biomass as the fuel of the future? As far as I am concerned, the trend in the production of energy from biomass is moving towards smaller, decentralized plants supplied with biomass from the immediate environment on short transport routes. This is also the preferred variant for farmers, the generators of the biomass, as they see the potential for becoming commercially involved themselves in selling their biomass. As far as obtaining energy from biomass is concerned, I am also in favour of using primarily waste types of biomass, and not just on ethical grounds. This prevents the production of food competing with the cultivation of biomass for fuel on existing agricultural land. In our ArtFuel plant this year, for example, we have successfully



Opening of the ArtFuel plant on 5th August 2005: Minister of the Environment Sander (centre) officially opened the plant by pressing the “red button”. At the front of the picture you can also see Mr Grübmeyer (left) and Prof. Carlowitz (right)

obtained Fischer-Tropsch fuels (diesel) from straw. Other substances such as methane, for example, can also be generated from a synthesized gas and this methane, just like the methane from fermentation plants, can be fed into the public gas supply network as a biogenic substitute for natural gas. The legal framework to foster such technologies has now also been introduced and provides financial incentives. Regardless of this, we must strive to design the associated processes to be as economic as possible. A number of years' further intensive research into the existing technical problems in optimizing the process and, probably, a further rise in oil prices, will be motivating factors here.

IN THIS ISSUE

- Fresh impetus: bioprocess technology at CUTEC 2
- News from the Forschungsverbund Energie Niedersachsen (FEN) 2
- Main topic
To stand still is to go backwards: new approaches for our § 26 measuring office 3
- The scientific advisory board at CUTEC: a profile of Prof. Dr. rer. nat Angelika Heinzel 4
- News from the CUTEC team 4
- International CUTEC activities, Autumn 2007 4

In order to be able to complete the biomass conversion chain (gasification, gas purification and synthesis) for decentralized plants, too, the development of a “gas purification” component is of key importance, especially from the points of view of minimizing investment costs and recycling the by-products created. In this connection, we applied to N-Bank for support for the ABSART project to develop and test a treatment technology for gases synthesized from biomass and its implementation in the ArtFuel process by way of an example. Initially, approval could not be given for this due to altered funding conditions, but Minister Sander had agreed to try to get funding and Secretary of State Dr. Eberl also indicated his support. We are now pleased to report that funding has been approved and would like to take this opportunity of passing on our thanks expressly to those in charge of Lower Saxony's Ministry of the Environment.

I wish you and all the staff at CUTEC a healthy and successful 2008.

Best wishes

Otto Carlowitz

Fresh impetus: bioprocess technology at CUTEC

Working party accredited by scientific advisory board

The history of bioprocess technology at CUTEC stretches as far back as the Nineties, when we gathered experience in developing compact bioreactors and in dynamic modelling of biological processes. On the basis of this experience, more and more new areas of research associated with bioconversion, recovery of valuable material, sensor development and alternative energy sources were opened up.

In 2004, the scientific advisory board recommended acquiring third-party funds to expand bioprocess technology at CUTEC by means of organic diversification. In subsequent years, extensive research funds were obtained, enabling us to develop, among other things, a powerful bioanalysis tool (UPLC-MS¹, FT-IR², microtiter plate reader, 2D gel electrophoresis etc). Meanwhile, bioprocess technology has become an integral part of basic CUTEC disciplines and forms the interface between biology and technology in the development of new environmental system and process technologies.

In August 2006, a new working party called "Bioprocess technology" was then set up at the CUTEC Institute within the "Physical and Biological Processes" department. The new working party is led by Dr. Schläfer.

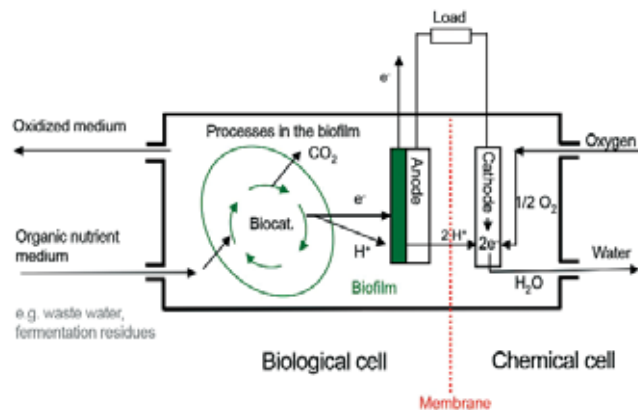

Diagram illustrating the function of a microbial fuel cell

In developing regenerative energy systems, bioprocess technology is currently directing its strategic focus at biomass conversion (fermentation) and microbial fuel cells (MFCs). An MFC contains living microorganisms which produce electrical current directly from complex organic substrates under very mild conditions.

Research into MFCs world-wide is still in its infancy, but initial results suggest enormous application potential, especially using substrates from waste water treatment and the treatment of fermentation residues from anaerobic production of methane.

An MFC on a laboratory scale was set up to examine this potential. The theoretical function of this fuel cell is shown in the diagram on the left.

The MFC consists of an anode compartment and a cathode compartment. Electrons generated by the metabolic activity of the microorganisms

under anaerobic conditions pass to the anode. A full electrical circuit is created by hydrogen ions reaching the cathode through a hydrogen ion-selective membrane and reacting with oxygen to produce water.

Initial results on the test bench are very promising. There are already research collaborations with the aim of developing process technology, reactor technology and bioprocess technology approaches to increasing the output of the fuel cell and, in the process, helping shape the development and implementation of MFCs from the outset. (schl)

News from the Forschungsverbund Energie Niedersachsen (FEN) research group

The Forschungsverbund Energie Niedersachsen [Lower Saxony Energy Research Group, or FEN for short] has been in existence since July 2006. As already reported in CUTEC NEWS 2/2006, ten sub-projects are looking at different issues associated with incorporating decentrally-generated energy into electricity networks. In Goslar in June 2007, researchers from the institutions involved gave an interested audience

papers on their individual sub-projects and an insight into their work at a conference, FEN's first status seminar. The expert reporters for this project are expected at the next status seminar, probably in Braunschweig in late May 2008 – they will then decide on whether the FEN project should be extended.

As part of the FEN project, CUTEC is expanding Clausthal energy park. A new block-type thermal power station, the Dachs HKA 5.5 from Senertec, has been integrated in the existing electric and thermal network of the energy park.

The intention is to expand the existing combined power and heat into combined power, heat and cold. An absorption cooling machine, the Chilli PSC 10 from Pink GmbH, has been purchased within the scope of FEN, as have a cooling tower and a cold accumulator. These components will be incorporated into the energy park over the next few weeks.

The absorption cooling machine is a single-stage absorption cooling machine using the two materials ammonia and water. The ammonia/water mixture is heated to boiling temperature in the expulsion unit (generator, boiler) with the aid of the waste heat from a block-type thermal power station (70 to 100 °C). The ammonia enters the condenser in the form of steam, where it condenses again at 25 to 30 °C. The condensed coolant ammonia is evaporated in the evaporator at low pressure (approx. 3 bar) at temperatures as low as 0 to 5 °C, allowing the production of cold water to air-condition premises. In the absorber, the cold ammonia steam is absorbed out of the operating solution which has only a low ammonia content. The solution, now rich in ammonia again, flows into the expulsion unit through the solution heat exchanger, in counter-current

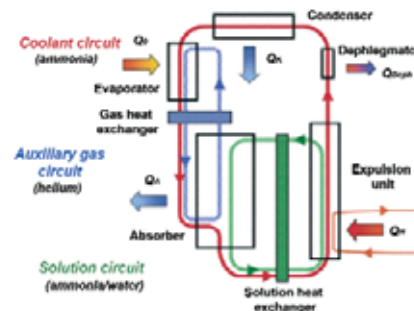

Single-stage continuous absorption cooling system

Continued on page 3

¹ UPLC-MS = Ultraperformance-Liquid-Chromatography / Mass-Spectroscopy, ² FT-IR = Fourier-Transformations-Infrarotspektroskopie

To stand still is to go backwards: new approaches for our § 26 measuring office:

If you can't measure it, you can't manage it

The job of the measuring office has always been to monitor emission limit values for operators of plants requiring permits. Precision and reliability of data have been and continue to be as important in determining dust content and gases as in the analysis of highly toxic trace substances in combustion gases. However, this was not enough for us – we were looking for new fields of activity to emphasize the significance of this organizational unit to CUTEC. Following restructuring and reorganization, the intention was to modify the measuring office in a meaningful way to suit the changed conditions of the market and our internal focus, as well as to redefine its strengths.



Committed and enjoying it: measuring emissions for a client

Initially, however, a number of obstacles had to be overcome: to obtain official recertification, measuring office staff received intensive quality management training. Newly-developed test methods had to be validated, internal routines optimized and tasks redistributed. All doubt was eliminated the day Hildesheim trading standards department came in to evaluate us: the CUTEC measuring office was certified for another five years.

To stand still is to go backwards – we have taken new approaches and consolidated the office as an indispensable part of the CUTEC whole. The measuring office is now continually acquiring new customers: honing its profile as a service element to accompany a project in association with other CUTEC departments has given the “§26ers” new significance right the way through from acquisition of a client to successful conclusion of the project. Clients are happy to confirm over and over again that our scheduling and project-related flexibility is one of the reasons for our success. This is regardless of whether the project involves checking the

increase in efficiency of incineration plants or verifying the emission of harmful substances following process optimization – the measuring office can be relied upon!

The acquisition of new customers proved necessary to increase the turnover of the measuring office, along the lines of: “if there's not enough coming out at the bottom, more needs to go in at the top”. To this end, a brochure was produced which highlights benefits for our customers – our unique selling points – as follows:

- our competence in process technology and plant engineering enables us to guarantee that customers will adhere to legally-specified measured values.
- we support our clients in understanding the problem, so helping them save time and money.
- we find funding options for our clients to render new methods and processes commercially viable.
- our thermal, physical and biological departments, together with chemical process technology, give us an in-depth understanding of our clients' production processes, allowing further optimization of processes to be achieved.

Following the appropriate market research, the brochure was sent to potential clients initially within Lower Saxony and Schleswig-Holstein. The result was a massive expansion of our customer base, with turnover of the measuring office all but doubling in 2007 (see diagram).

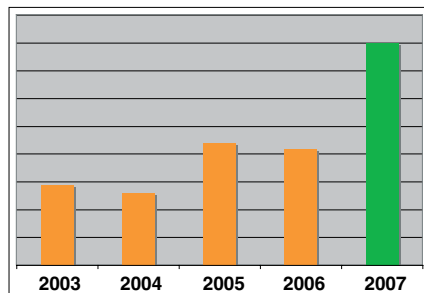

Growth in turnover for the measuring office

Internally, we have also taken the initial steps required for us to manage this increased order volume – for example, expanding the customer database. Consequently, incoming orders can now be processed even more rapidly without sacrificing our high standards of quality.

The measuring office contributes to better use of finite resources or to their being replaced by regenerative fuels; in this way, we make an active contribution to reducing CO₂ emissions.

In the final analysis, the measuring office is CUTEC's sensor on the pulse of other companies, the first to notice potential problems and communicate them throughout CUTEC; this will enable CUTEC to continue at the vanguard in providing innovative solutions in future.

(sr/fi/wei)

Continuation from page 2 News from the Forschungsverbund Energie Niedersachsen (FEN)

to the heated low-ammonia solution. The process starts again from the beginning. The absorption cooling machine takes the heat it needs from the existing heat accumulators which are stocked by the thermal energy of the block-type thermal power stations. The running time of the integrated Dachs block-type thermal power station is controlled by the storage temperature. The plan is to develop a management system for the thermal sectors of the energy park like that already in existence for the electrical sectors. In future, this will allow the combined power, heat & cold of the energy park to be visualized, balanced and controlled by this management system. (sen)

IMPRINT

Published by: CUTEC-Institut GmbH

Editor: Dr. T. Heere

Contributors:

Prof. Dr.-Ing. O. Carlowitz (ca)

Dr. A. Fischer (fi)

Dr. T. Heere (he)

Dr.-Ing. T. Onyeche (on)

Dipl.-Kaufm. A. Sauter (sr)

Dr. O. Schläfer (schl)

Dipl.-Ing. N. Senkel (sen)

W. Weber-Kubitzi, B.A. (wb)

Dr.-Ing. S. Weineck (wei)

Dr. T. Zeller (ze)

Layout and typesetting: G. Wessels (wes)

Photos: G.-E. Knochen (kn)

Production and supply:

CUTEC-Institut GmbH

Leibnizstr. 21+23

38678 Clausthal-Zellerfeld

Tel. +49 5323 933-0 · Fax +49 5323 933-100

E-mail: cutec@cutec.de

Internet: www.cutec.de

Publication:

Several times a year at irregular intervals. Issues can be ordered from the address above at no charge.

Send an E-mail to: cutec-news@cutec.de

Scientific advisory board at CUTEC:

a profile of Prof. Dr. rer. nat Angelika Heinzl



Prof. Angelika Heinzl

Professor Angelika Heinzl has been a professor with the chair for Energietechnik [Energy Technology] at the University of Duisburg-Essen since 2001. At the Institut für Energie- und Umweltverfahrenstechnik (Abteilung Maschinenbau) [Institute of Energy and Environmental Process Technology (Engineering Department)] of the Engineering Sciences Faculty, her research activities focus on fuel cell and hydrogen technology. Her department has many spheres of competence, particularly in relation to the generation of hydrogen, heterogeneous catalysis and developing materials for fuel cells. Simultaneously since January 2002, Prof. Heinzl has been managing director of the scientific activities of the Zentrum für Brennstoffzellen Technik [Centre for Fuel Cell Technology – ZBT], a non-profit making GmbH, whose sole shareholder is the University of Duisburg-

Essen. The ZBT is a facility with a wide spectrum of technologies, as the umbrella term “fuel cell technology” covers all aspects of the fuel cell as well as all the peripherals associated with it. After completing ‘A’ levels in 1974, Prof. Heinzl first studied at Münster, followed by chemistry at Kiel where she also obtained her diploma in 1980 before switching to Oldenburg to study for her doctorate. She graduated from there in 1985 with a thesis on the electrooxidization of low molecular-weight C,H,O compounds, most specifically methanol. Following her doctorate, that same year she moved to the Fraunhofer-Institut für Solare Energiesysteme [Fraunhofer Institute for Solar Energy Systems – ISE] in Freiburg, where she researched into battery and fuel cell development and became director of the energy technology department in 1997 before being called to the professorship mentioned at the beginning in 2001. For over ten years, Prof. Heinzl has also been a member of various committees and special interest groups, as well as an expert reporter in industrial community research for the AiF. Prof. Heinzl was invited onto CUTEC’s Science Committee by Prof. Carlowitz. Her initial contact with CUTEC had come about some time before when Prof. Carlowitz visited the ZBT; this gave rise to an idea for a project, now realized, which created good contacts between the two bodies. Asked about the nature and objectives of her involvement with the scientific advisory board at CUTEC,

Prof. Heinzl responded: “As the ZBT has expertise in the field of fuel cell technology, I hope that further synergies will result between CUTEC and ZBT so that our collaboration can be extended beyond this initial project. I believe that a cross-regional research network is a worthy objective in the continued development of fuel cell technology. CUTEC is an important contact for us in this field in Lower Saxony because it is perfectly networked with the other members of the Lower Saxony fuel cell network. I think this may create good opportunities for CUTEC to acquire fuel cell projects in future, with or without the participation of the ZBT. I am particularly pleased that there is already a lively exchange of ideas between staff from both bodies at a variety of levels.” (he)

News from the CUTEC team



Dipl.-Chem. Jana Oelze

Dipl.-Chem. Jana Oelze joined the Chemical Process Technology department on 1st November 2007. Ms Oelze studied at the Technical University of Clausthal where she achieved her diploma in chemistry – and she was working for us as a scientific assistant even then. Following her studies, Ms Oelze worked at the university’s Institut für Anorganische und Analytische Chemie [institute of inorganic and analytical chemistry] as a scientific assistant. At CUTEC, one of her areas of research will be high-temperature fuel cells. (wes)

CUTEC’s International activities, Autumn 2007

In September 2007, Dr.-Ing. Theodore Onyeche, Manager International Operations, represented CUTEC in a business delegation to Canada led by the Lower Saxony minister for Economic Affairs, Labour and Transport, Mr Walter Hirche. Meetings in Vancouver, Calgary and Toronto provided the opportunity to exchange ideas and opinions with Canadian professionals on the current environmental situation as well as the need for CUTEC technologies in Canada. Dr. Onyeche was very satisfied with the outcome of the trip which was excellently organized by the Ministry of the Economic Affairs, Labour and Transport, the International Chamber of Commerce in

Hannover and the Chamber for Foreign Trade in Canada. This resulted to the acquisition of a large number of new and important contacts for CUTEC.

In October, CUTEC also participated in the EnviroMaroc trade fair in Morocco for the first time and represented by Dr. Onyeche and Ms Weber-Kubitzki. The EnviroMaroc exhibition in Casablanca is one of the most important environmental technology events in the Maghreb region. As a consequence of the growing environmental awareness, many guests visited the CUTEC stand to intimate themselves with CUTEC’s solutions in environmental and renewable energy technologies. (on/wb)

Enclosed with this issue:

Prof. Reuter awarded the defence industry’s technology prize for 2007

Prof. Reuter awarded the defence industry's technology prize for 2007

Award made for "Humanitarian Mine-Clearing" project



In 2005, the 50th anniversary celebrations of the formation of the German Bundeswehr [armed forces] were the backdrop for the defence industry's technology prize being awarded for the first time by the Ausschuß der Verteidigungswirtschaft [Defence Industry Committee – AVW] of the Bundesverband der Deutschen Industrie [Confederation of German Industry - BDI], with BDI President Jürgen Thumann presiding. This award, worth a total of € 20,000, was intended to reward outstanding innovative performance in safety/defence technology to promote Germany's internal and/or external security provision.



The 2007 award winners

The main prize was awarded for the second time on 29th November at the Haus der Deutschen Wirtschaft [German Economics Centre] in Berlin; it honoured the work of Prof. Matthias Reuter in the field of humanitarian



Land mines are a deadly danger, claiming some 25,000 lives every year

mine-clearing. The jury highlighted the innovative idea of using computer-aided, self-adapting methods for tracing land mines. A relic of armed struggles, these mines present a hazard to the populations of many countries of the world and are a barrier to rebuilding the infrastructure – reliable mine-clearing is absolutely essential.

Metal detectors are most frequently used to trace mines, but have the drawback of a high number of false alarms. Prof. Reuter and his team succeeded in reducing this number significantly using computational intelligence (CI) – and special neural networks as well – significantly increasing the reliability of mines being discovered.

As first field trials demonstrated, equipping commercial metal detectors with artificial intelligence (AI) modules also enables them to be set locally to suit the types of mine to be traced, expanding their use to previously unknown kinds of anti-personnel mine. This software also allows geological and weather-related anomalies of the soils being scanned to be extracted as irrelevant in the search for mines.

In another innovative step, AI can be used to assign mines to their actual positions and depths for the first time and to detect mine-like structures.

The classification and identification power a mine-seeker acquires in the field by these means can then also be transmitted to other mine-seeking equipment or to a central management point by mobile phone, for example, allowing an expanding expert system to be built up gradually.

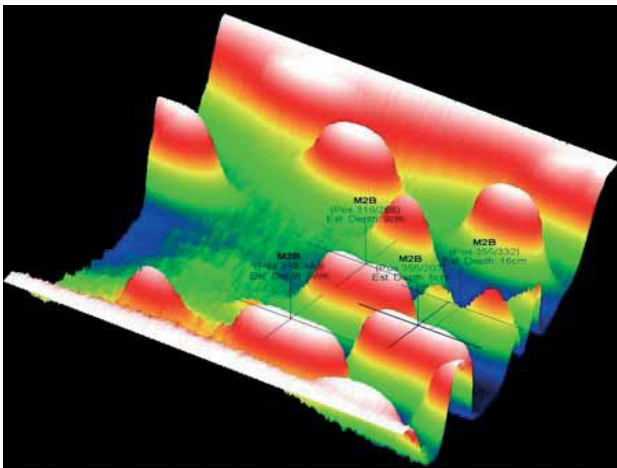

Visualizing classification results with position and depth determination using the example of one type of mine and actual measured data

However, the process given this year's award can be applied to more than just mine-seeking; it can also be used for acoustic location and identification of helicopters and aircraft and for tracking down explosives.

The award-winning AI algorithms were developed in the course of the collaborative project

entitled "Metalldetektoren für Humanitäres Minenräumen – Entwicklungspotenziale für Datenanalyse und Messtechnik: Teilprojekt Verbund-Koordination; modellbasierte Objekt-Klassifikation; Orts- und Lage-Bestimmung" [*Metal detectors for humanitarian mine-clearing – development potential for data analysis and measuring technology: sub-project: group coordination; model-based object classification; determining location and position*] funded by the BMBF [*Bundesministerium für Bildung und Forschung – Federal Ministry of Education and Research*].



Apl. Prof. Dr.-Ing.
Matthias Reuter

After studying physics and geophysics, Prof. Reuter completed a doctorate in physical chemistry. Over the next few years, there followed appointments as a scientist at the Universität der Bundeswehr [*Armed Forces' University*] in Hamburg, the Technical University of Clausthal and the University of Dortmund, where his work in these exclusively research-based jobs focussed on neural networks and artificial cognitive systems. In pursuing these areas of special interest, Prof. Reuter wrote his professorial thesis on practical information technology and in 2006, was appointed apl. Professor [*adjunct professor*] at the Technical University of Clausthal. His scientific activities range from neural-based monitoring of vital parameters to robot football and predictive control of industrial plant. Prof. Reuter has run CUTEC's Modelling and Simulation department for five years and also chaired numerous international organizations for many years. He lectures at the Institut für Informatik [*Information Technology Institute*] at the Technical University of Clausthal and is a permanent adviser to Deutsche Bahn AG.